

DH-PFA135

Water-proof Junction Box



Features

Neat & Integrated design .

Material: Aluminum

Water -proof Junction box

Camera Mount Series | DH-PFA135

Technical Specifications

Model	DH - PFA13 5
General	
Material	Aluminum
Dimension	φ90mmx34.1mm(φ3.54"x1.34")
Inch Thread	M20(G1/2")
Load Bearing	1.0kg(2.2lb)
Weight	0.16kg(0.35lb)
Color	Black
Operating Temperature	-40°C~+60°C(-40 ~+140)
Humidity	0~90% RH
Applicable Model	Please see "Accessory Selection"

Order Information

Type	Part Number	Description
Camera mount	DH - PFA135	Water -proof Junction box _ Dahua brand
	PFA135	Water -proof Junction box _ Neutral, no brand

Dimensions (mm /inch)

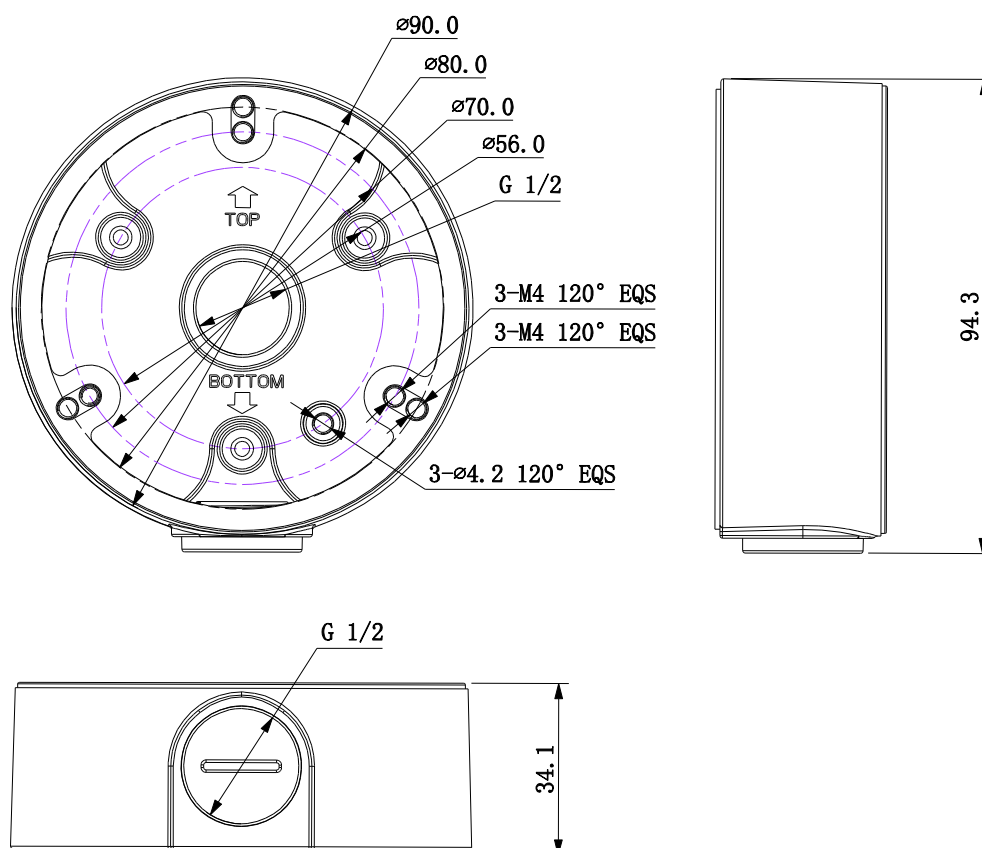

Application

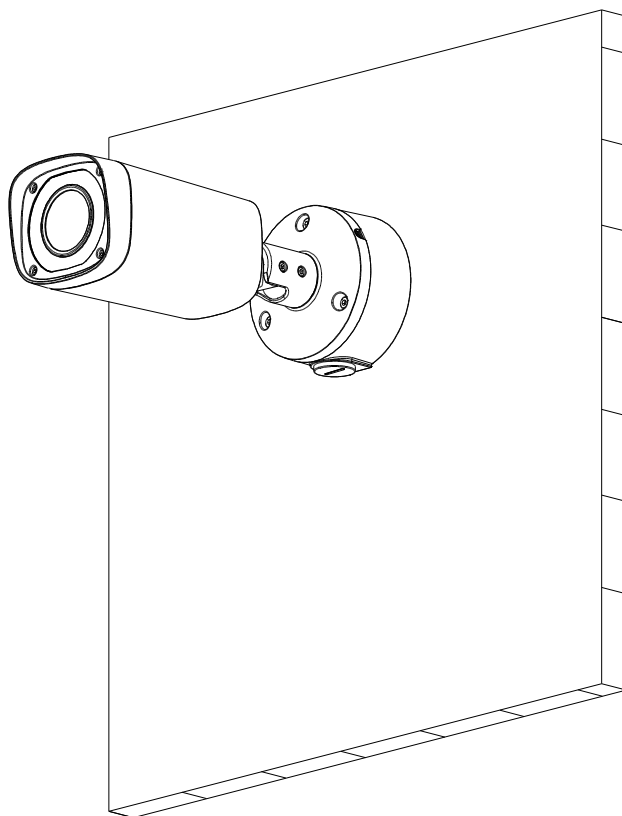

Package Information

- Water-proof junction box *1
- M4x10 screw *3
- ST4x25 screw *3
- Plastic anchor *3
- Water Joint *1
- Wrench *1

Package data	
Box Dimension	115mmx115mmx45mm(4.53"x4.53"x1.77")
Box Weight	0.2kg (0.44lb)
Protective Box Dimension	523mmx497mmx140mm(20.59"x19.57"x5.51")
Box In Protective Box	40 In 1